

ASCIONTM

Enterprise



POWERFUL



COMPLETE RANGE



RELIABLE AND STURDY



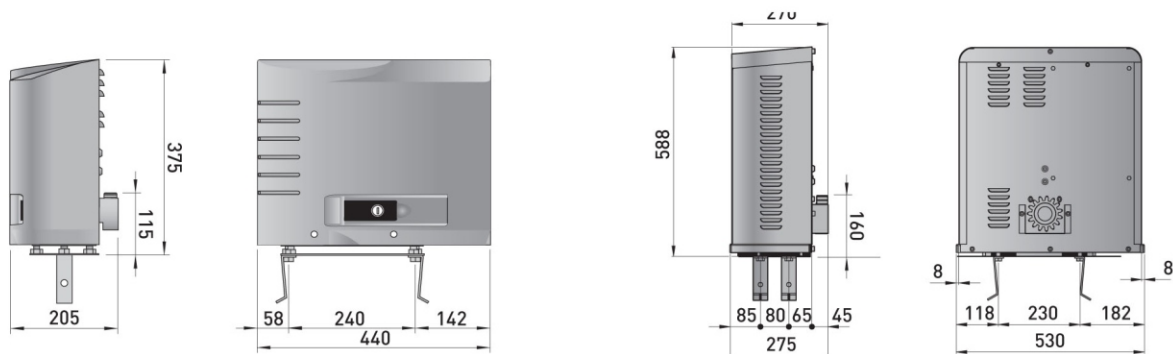

Technical specifications

Description	Cross 18	Cross 18E	Cross 18VE	Cross 19V	Cross 30E
Max. leaf weight	1800 kg	1800 kg	1800 kg	1800 kg	3000 kg
Stroke control	rotary limit switch	lever-operated limit switch	magnetic limit switch	magnetic limit switch	magnetic limit switch
Duty class	4 - heavy duty	4 - heavy duty	4 - heavy duty	4 - heavy duty	5 - very heavy duty
Intermittent operation	S2 = 30 min S3 = 50%	S2 = 30 min S3 = 50%	S2 = 30 min S3 = 50%	S2 = 30 min S3 = 50%	S3 = 100%
Power supply	230 V AC - 50 Hz	230 V AC - 50 Hz	230 V AC - 50 Hz	400 V AC - 50 Hz	400 V AC - 50 Hz
Power input	3 A	3 A	3 A	1.2 A	2.1 A
Thrust	1200 N	1200 N	1200 N	1500 N	3000 N
Opening and closing speed	0.2 m/s	0.2 m/s	0.2 m/s	0.2 m/s	0.16 m/s
Maximum opening	11 m	20 m	20 m	20 m	20 m
Release system for manual opening	key-operated	key-operated	key-operated	key-operated	lever
Automation system protection rating	IP 24D	IP 24D	IP 24D	IP 24D	IP 45
Operating temperature	-20°C / +55°C [-35°C / +55°C with NIO enabled]				-20°C / +55°C
Control panel	E1A or LOGICM (on request)	E1A (integrated)	LOGICM (integrated)	E1T (on request)	E1T (integrated)

Main functions of the system

Control panel	E1A	LOGIC M	E1T
Radio incorporated	■	on request	on request
Mains power supply	230 V AC / 50/60 Hz	230 V AC / 50/60 Hz	230 V AC / 50/60 Hz
Motor power supply	230 V AC / 5 A	230 V AC / 1 x 5 A	400 V AC / 6 A
Accessories power supply	24 V DC / 0.5 A	24 V DC / 0.5 A	24 V DC / 0.5 A
Flashing light	230 V AC	230 V AC e 24 V DC	24 V DC
Gate open warning light	limit switch	limit switch and analogue	limit switch
Courtesy light	■	■	
Limit-switch provision	■	■	■
Force setting	transformer	transformer	
ODS - Obstruction Detection System	■	■	
Time setting	■		
Open control	■ (with dip-switch)	■	■ (with dip-switch)
Partial opening control	■ (remote control only)	■	■
Close control	■	■	■
Timer controlled automatic closing	■	■	■
Inching control	■	■	■
Hold-to-run control	■	■	■
Emergency stop	■	■	■
Emergency reverse	■	■	■
Safety test function	■	■	■

FULL COMPLIANCE WITH EU DIRECTIVES AND STANDARDS

- 2014/30/EU - EMCD - Electromagnetic Compatibility Directive
- 2014/53/EU - RED - Radio Equipment Directive
- 2006/42/CE - Machines Directive - (Annex II-B; Annex II-A; Annex I-Chapter 1)

ASCON ENTERPRISE

77A/ 22, Raja S. C. Mullick Road, Kolkata- 700092

Tel: 033 2413 7160 M# +91 98300-39931 / 94335-56655 / 90736-79221

e-mail : asconsanjib@gmail.com Web. www.asconenter.com